

92mm sq.

San Ace 92

25mm thick (GA type), 25mm thick (S type)
 25mm thick, 25mm thick (San Cooler)
 32mm thick (G type), 38mm thick (GA type)
 38mm thick (GV type), 38mm thick (G type)



General Specifications

- Material Frame: Plastics (Flammability: UL94V-0),
 Impeller: Plastics (Flammability: UL94V-1)
- Expected Life Refer to specifications (L10:Survival rate:90% at 60°C ,
 rated voltage, and continuously run in a free air state)
- Lead Wire ⊕red ⊖black or blue (Sensor) yellow
- Storage Temperature -30°C to +70°C (Non-condensing)

92×92×32mm (Mass : 170g) **G type**

Specifications

The following nos. **have pulse sensors and ribs**. For ribless, append "1" to the model no.

Model No.	Rated Voltage [V]	Operating Voltage Range [V]	Rated Current [A]	Rated Input [W]	Rated Speed [min ⁻¹]	Max. Air Flow [m ³ /min] [CFM]	Max. Static Pressure [Pa] [inchH ₂ O]	SPL [dB(A)]	Operating Temperature [°C]	Expected Life [h]
9G0912A201	12	10.2 to 13.8	0.58	6.96	4,300	2.50 88.3	115 0.462	44	-20 to +70	40,000
9G0912S201			0.38	4.56	3,500	2.00 70.7	77 0.309	38		
9G0912H201			0.23	2.76	2,850	1.59 56.2	51 0.205	32		
9G0912M201			0.13	1.56	2,100	1.20 42.4	27 0.108	25		
9G0924A201	24	20.4 to 27.6	0.30	7.20	4,300	2.50 88.3	115 0.462	44	-20 to +60	
9G0924S201			0.19	4.56	3,500	2.00 70.7	77 0.309	38		
9G0924H201			0.12	2.88	2,850	1.59 56.2	51 0.205	32		
9G0924M201			0.08	1.92	2,100	1.20 42.4	27 0.108	25		
9G0948A201	48	40.8 to 55.2	0.16	7.68	4,300	2.50 88.3	115 0.462	44	-20 to +70	
9G0948S201			0.11	5.28	3,500	2.00 70.7	77 0.309	38		
9G0948H201			0.08	3.84	2,850	1.59 56.2	51 0.205	32		
9G0948M201			0.05	2.40	2,100	1.20 42.4	27 0.108	25		

Available options: ⇒ **Without Sensor**

Please inquire as the availability of these functions depend on the model. ⇒ **Lock Sensor** **Low speed Sensor** **PWM Control**

Dimensions (Unit : mm) (With ribs)

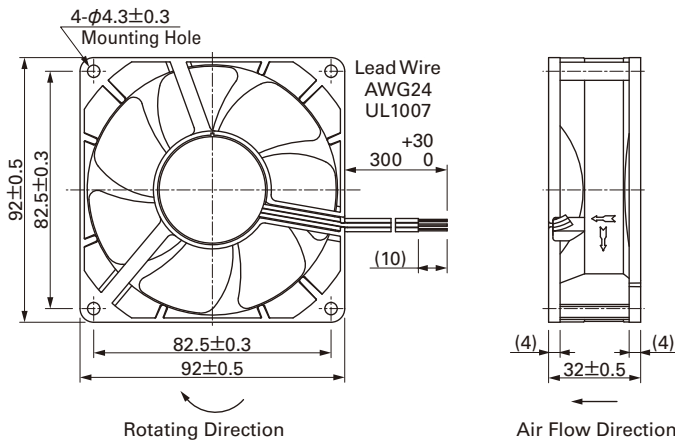

Reference dimension of mounting holes and vent opening (Unit : mm)

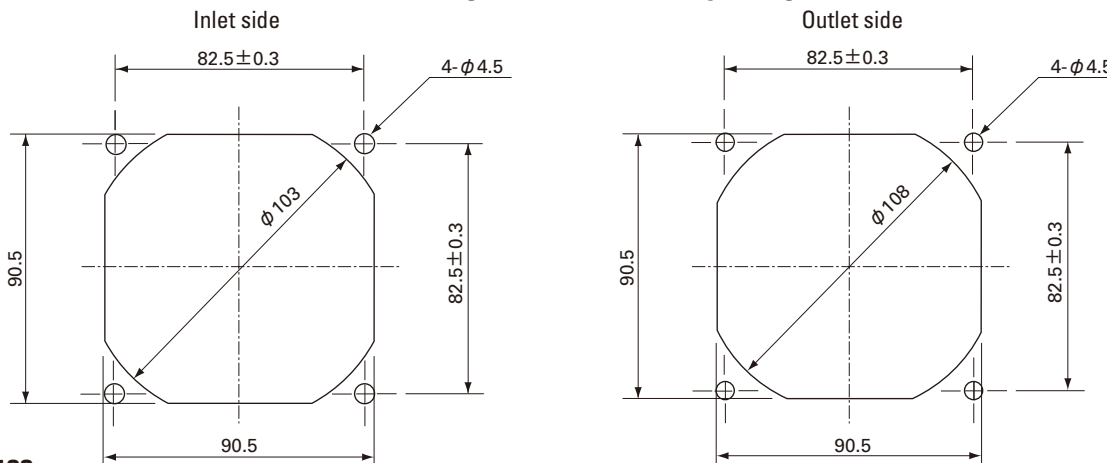

Options (Unit : mm)

Finger guards

Model : 109-099C Color : Nickel-chrome plating (silver)

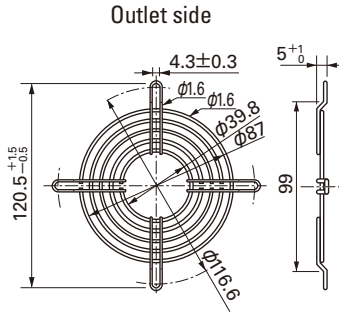

Resin finger guards

Model : 109-1001G

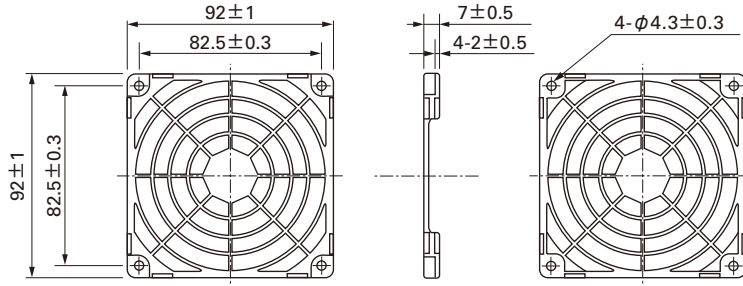

Model : 109-099E Color : Nickel-chrome plating (silver)
 : 109-099H Color : Cation electropainting (black)

Resin filter kits

Model : 109-1001F13 (13PPI), 109-1001F20 (20PPI)
 : 109-1001F30 (30PPI), 109-1001F40 (40PPI)

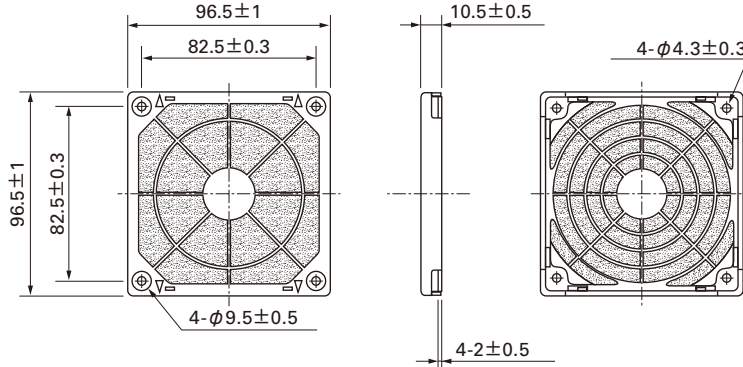
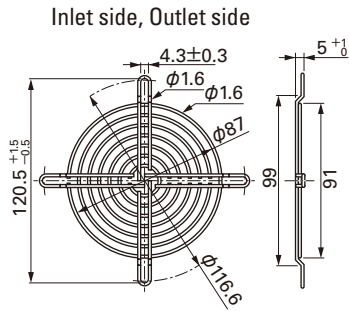

Air Flow - Static Pressure Characteristics

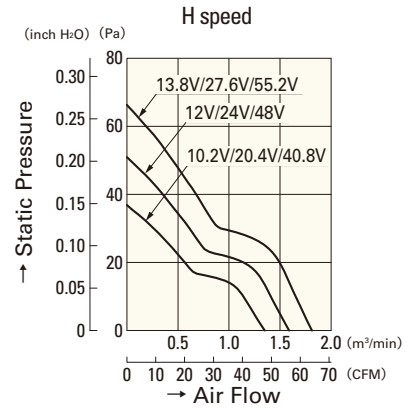
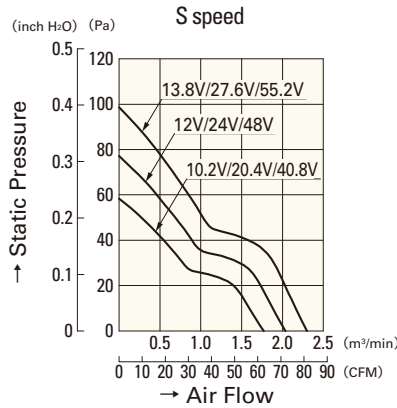
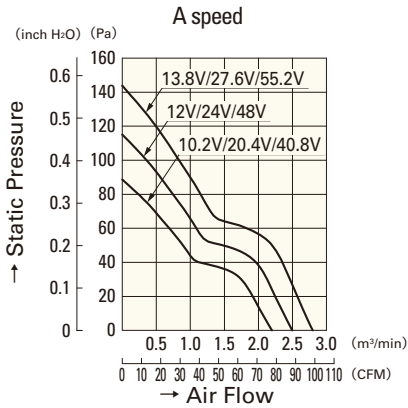

- 9G0912A201
- 9G0924A201
- 9G0948A201

- 9G0912S201
- 9G0924S201
- 9G0948S201

- 9G0912H201
- 9G0924H201
- 9G0948H201

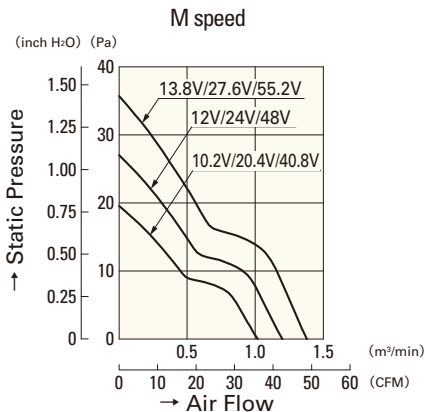

- 9G0912M201
- 9G0924M201
- 9G0948M201