

Ø 150x35 mm

San Ace 150W 9W2TN type  

DC
Splash Proof Centrifugal Fan Ø150 mm

General Specifications

- Material Motor case: Aluminum (Black coating), Impeller: Plastic (Flammability: UL 94V-0)
- Expected life See the table below. (L10 life: 90% survival rate for continuous operation in indoor free air at 60°C, rated voltage)
Expected life at 40°C is for reference only.
- Motor protection function Locked rotor burnout protection, Reverse polarity protection
For details, please refer to p. 608.
- Dielectric strength 50/60 Hz, 500 VAC, for 1 minute (between lead wire conductors and motor case)
- Insulation resistance 10 MΩ min. at 500 VDC (between lead wire conductors and motor case)
- Sound pressure level (SPL) A-weighted sound pressure level (SPL) at 1 m away from the air inlet.
- Storage temperature -30 to +70°C (Non-condensing)
- Lead wire ⊕Red ⊖Black (Sensor) Yellow (Control) Brown
- Mass 360 g
- Ingress protection IP68 For more information on IP rating, refer to p. 617.

Specifications When the optional inlet nozzle (109-1081H) is mounted.

The models listed below **have a pulse sensor with PWM control.**

Model no.	Rated voltage [V]	Operating voltage range [V]	PWM duty cycle [%]	Rated current [A]	Rated input [W]	Rated speed [min ⁻¹]	Max. airflow [m ³ /min] [CFM]	Max. static pressure [Pa] [inchH ₂ O]	SPL [dB (A)]	Operating temperature [°C]	Expected life [h]
9W2TN24P1H001	24	20.4 to 27.6	100	0.64	15.4	3800	3.83 135	390 1.57	59	-20 to +70	40000/60°C (70000/40°C)
			20	0.16	3.84	1500	1.51 53	60.7 0.24	38		
9W2TN48P1H001	48	36 to 55.2	100	0.32	15.4	3800	3.83 135	390 1.57	59		
			20	0.08	3.84	1500	1.51 53	60.7 0.24	38		

* PWM frequency is 25 kHz. Models without ratings for 0% PWM duty cycle have zero speed at 0%. When control terminal is open, speed is the same as at 100% duty cycle.

Note 1: Max input is 22 W at rated voltage.

Note 2: The  mark indicates Short LeadTime Service applicable models. See p. 664 for details.

Airflow - Static Pressure Characteristics / PWM Duty - Speed Characteristics Example

9W2TN24P1H001 With pulse sensor with PWM control

PWM duty cycle

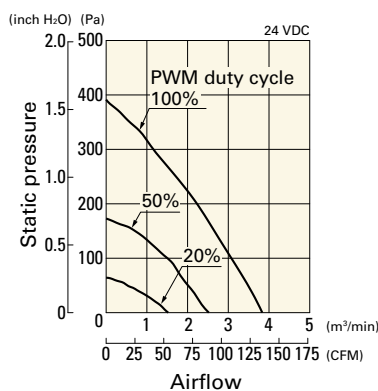

Operating voltage range

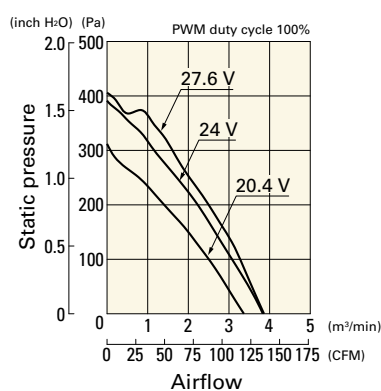

PWM duty - Speed characteristics example

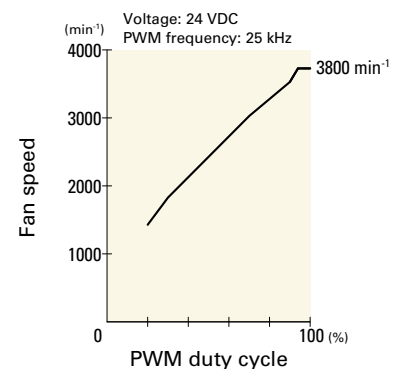

Airflow - Static Pressure Characteristics / PWM Duty - Speed Characteristics Example

9W2TN48P1H001 With pulse sensor with PWM control

PWM duty cycle

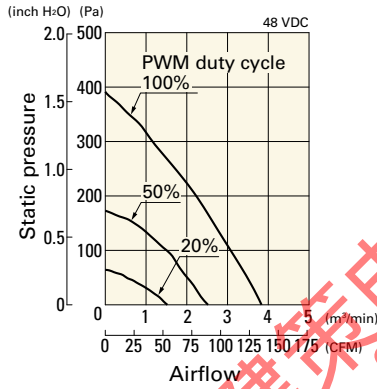

Operating voltage range

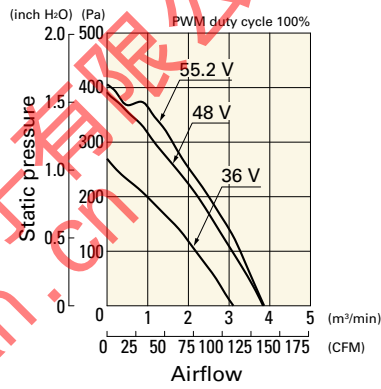

PWM duty - Speed characteristics example

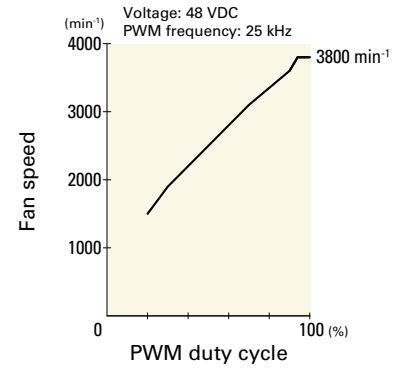

Dimensions (unit: mm)

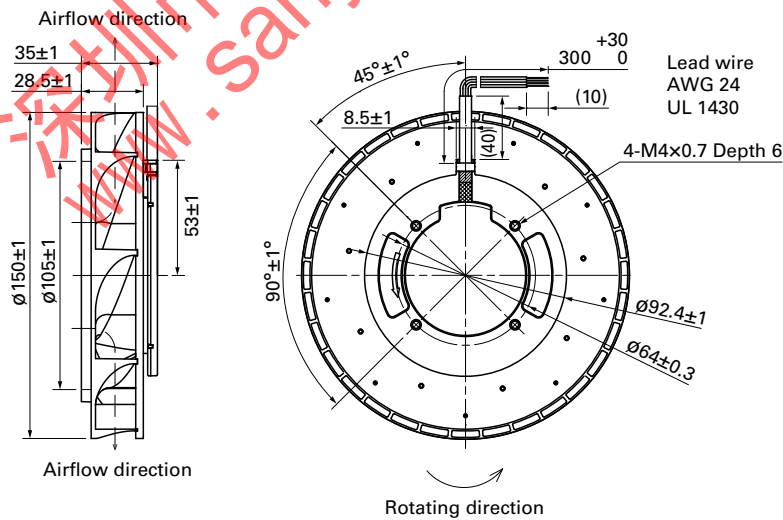

Reference Dimensions of Mounting Holes and Vent Opening (unit: mm)

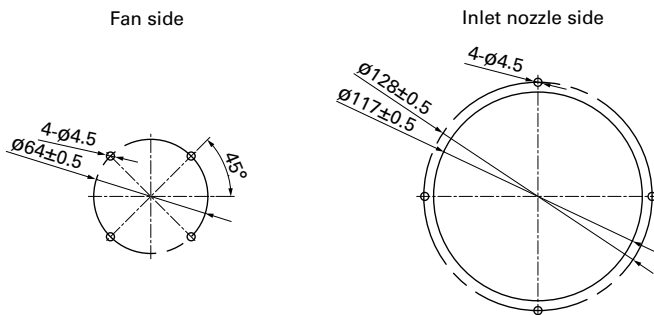

Reference Diagram for Mounting (unit: mm)

